

COMMERCIAL

H270TGNBT 20'

H270TPH 20'

H370TGNBT 24'

H370TGN 30'

The Trailtech Commercial series trailers deliver durability, reliability and serviceability in each model. For general farm, hotshot or long haul trucking, the Commercial series trailers are available in a range of models to match your range of loads. The gooseneck hitch makes for smooth, easy pulling either across the field or down the highway. Pintle hitches are also available, allowing you to match the trailer to any tow vehicle.

The Commercial series trailer, like all Trailtech trailers, uses electrical and brake wiring which runs through a shielded main cable secured to the trailer by rubber insulated loom clamps. The cable is further protected by rubber grommets when passing through any holes in the framing, providing extensive protection to the trailer's wiring system. These highboy trailers are constructed with a heavy-duty 10" I-beam main frame and complimented with standard Trailtech conveniences, such as stake pockets with rub rail for added protection and security of your load.



Durability & Reliability



Trailtech Inc.

Box 988, Gravelbourg, SK, Canada S0H 1X0
P: (306) 648-3158 | F: (306) 648-3305

 **TRAILTECH**
www.trailtech.com

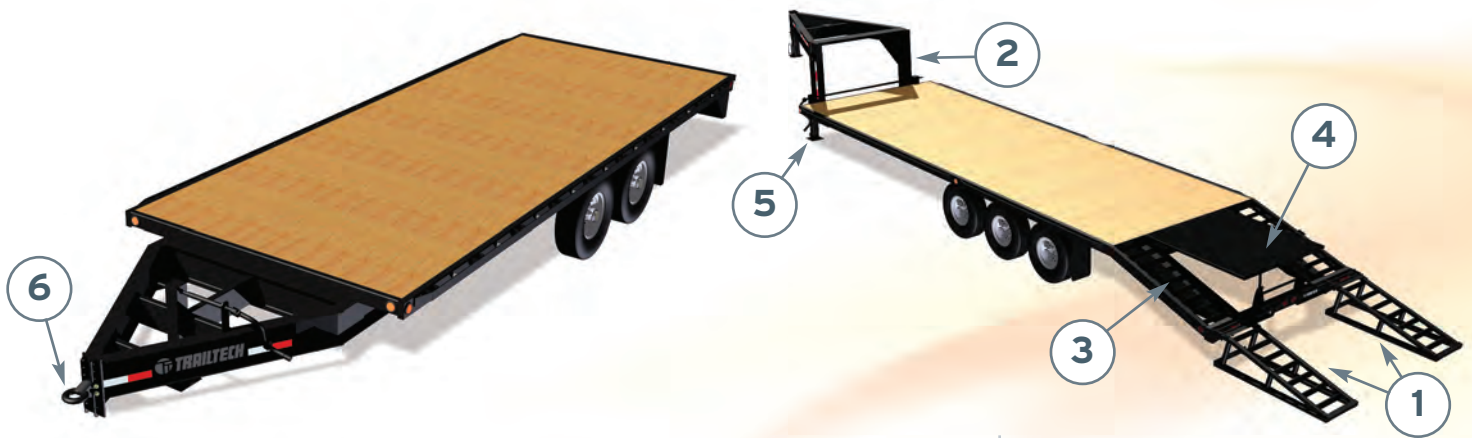

1) Beavertail & Double Pivot Ramps

The 5' Beavertail creates an ideal loading incline combined with the ease of spring assisted ramps.



2) Steps & Grab Handles

Gooseneck step and grab handles make it easier and safer to get up on to the trailer deck.



3) Open Cleated Beavertail

The Open Cleated Beavertail eliminates the slippage common on wooden beavertails.



4) Spring Assisted Flip Up Center

It is now easier than ever to extend the length of your deck with the spring assisted flip up centre.



5) Dual Drop Foot Jacks

Dual HD Drop Foot Jacks and Expanded Metal Basket are standard on all Goosenecks, for increased stability, lift and storage capacity.



6) Hitches

Models are available with either pintle or gooseneck hitches allowing you to match any tow vehicle requirements.

| Features | H270TPH 20' | H270TGNT 20' | H370TGNT 24' | H370TGN 30' |
|--|--|---|---|---|
| Main Frame | 10" I-beam | 10" I-beam | 10" I-beam | 10" I-beam |
| Structural Tubing Crossmembers | 3 x 2 x .125 | 3 x 2 x .125 | 3 x 2 x .125 | 3 x 2 x .125 |
| Axles | (2) 7000 lb Rubber Ride Electric Braking | (2) 7000 lb Rubber Ride Electric Braking | (3) 7000 lb Rubber Ride Electric Braking | (3) 7000 lb Rubber Ride Electric Braking |
| Overall Width | 102" | 102" | 102" | 102" |
| Deck Height | 38" | 38" | 38" | 38" |
| Gooseneck Coupler | - | 2 5/16" | 2 5/16" | 2 5/16" |
| Pintle Hitch with Adjustable Lunette Eye | Standard | - | - | - |
| Tires (Radial) | ST235/80R16 | ST235/80R16 | ST235/80R16 | ST235/80R16 |
| Slide in Ramps | Standard | - | - | Standard |
| Beavertail & Double Pivot Ramps | - | Standard | Standard | - |
| Options | - | Spare Tire, Rim & Carrier, Gooseneck King Pin | Spare Tire, Rim & Carrier, Gooseneck King Pin | Spare Tire, Rim & Carrier, Gooseneck King Pin |
| Curb Weight | 4225 lb | 4674 lb | 5335 lb | 6382 lb |

* All models come standard with: LED Lights, 12,000 lb Side crank jack, Treated wood deck, Rub rail c/w stake pockets, White spoke rims w/chrome centers.