



All-Aluminum Horse Trailers Made in New England

# AMBASSADOR SERIES



Ambassador 67" Tack Model Shown



## ~ STANDARD FEATURES ~

HORSE AREA

FRONT TACK AREA

	44" Tack Model	67" Tack Model	67" Tack w/ Manger Model
Solid Head and Shoulder Dividers w/ Butt bar & Breast bar	X	X	X
Large Sliding Window w/ Screen and Bars per Stall	X	X	X
Drop Down Feed Door per Stall			X
Feed Manger per Stall			X
1/2" Rubber Floor Mats	X	X	X
Heavy Duty Wall Liner (Double Wall Construction)	X	X	X
Spring Loaded Rear Ramp (Rubber Lined) w/ Wrap Around Tail Curtains	X		
Spring Loaded Rear Ramp (Rubber Lined) w/ Wrap Around Tail Curtains, Sliding Windows & Bars		X	X
2 Inside Tie Rings and 1 Outside Tie Ring per Horse	X	X	X
3 Interior Dome Lights in Horse Area w/ Rear Loading Switch	X	X	X
Double Action, Pop-up Vent per Horse Stall	X	X	X
32" x 72" Escape Door	X		
32" x 72" Side Access Door w/ Sliding Windows & Screen (2)		X	
32" x 72" Tack Storage Door in V-Nose	X		
32" x 72" Tack Storage Door in V-Nose w/ Sliding Window		X	X
20" x 72" Pass Thru Door to Horse Area			X
1/2" Rubber Floor Mats	X	X	X
1 Interior Dome Light in Tack Area w/ Wall Switch	X	X	X
6 x Adjustable Bridle Hooks	X	X	X
Wall-Mounted Blanket Bar	X	X	X
Brush Tray Mounted on Tack Storage Door	X	X	X
One Adjustable/Removeable Saddle Rack per Stall	X	X	
Pull-Out Saddle Rack per Stall (Stores Under Manger)			X
(2) Sliding Windows in Tack Wall w/ Bars		X	X
(2) Sliding Windows w/ Screen in V-Nose		X	X





All-Aluminum Horse Trailers Made in New England

# AMBASSADOR SERIES

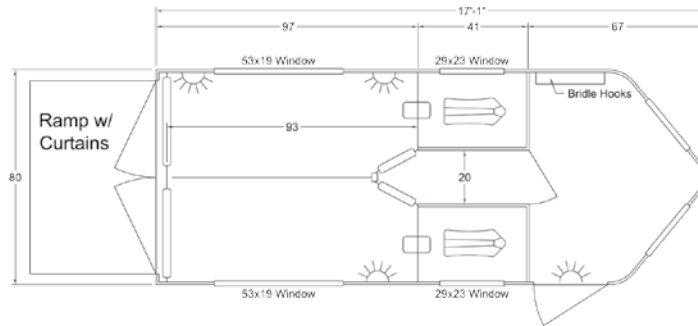
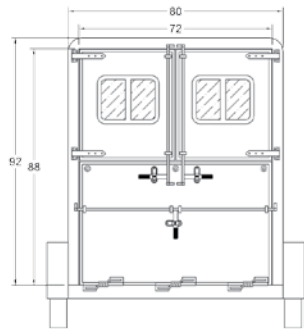
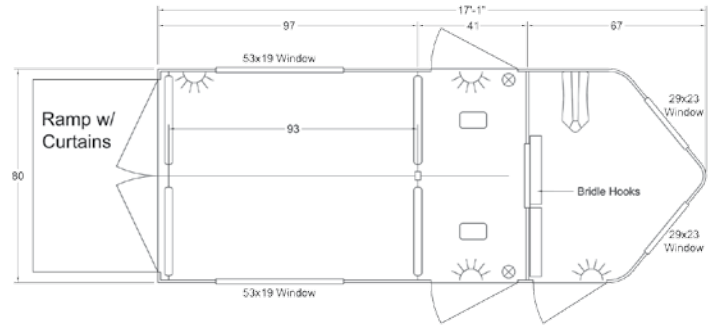
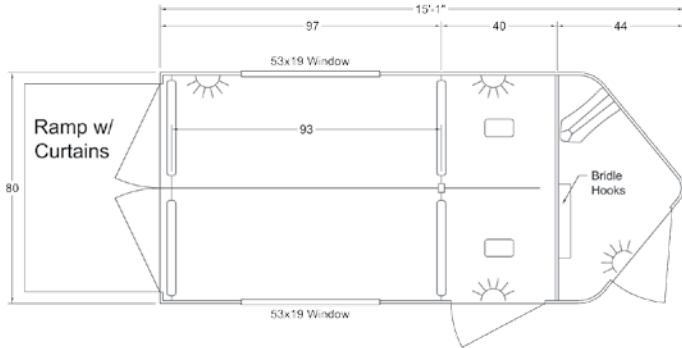

## ~ STANDARD SPECIFICATIONS ~

	44" Tack Model	67" Tack Model	67" Tack w/ Manger Model
Coupler:	Bumper Pull, 2 5/16"	Bumper Pull, 2 5/16"	Bumper Pull, 2 5/16"
Box Length:	14'7"	16'7"	16'7"
Trailer Width:	6'8"	6'8"	6'8"
Inside Height:	7'6"	7'6"	7'6"
Number of Horses:	2	2	2
Load Type:	Straight Load - Rear Ramp	Straight Load - Rear Ramp	Straight Load - Rear Ramp
Stall Width:	37 1/2"	37 1/2"	37 1/2"
Stall Length:	84"	84"	84"
Style:	Bumper Pull, V-Nose Construction with 24" Stone Guard	Bumper Pull, V-Nose Construction with 24" Stone Guard	Bumper Pull, V-Nose Construction with 24" Stone Guard
Construction:	100% Box Tube Aluminum Fully Intergrated Frame	100% Box Tube Aluminum Fully Intergrated Frame	100% Box Tube Aluminum Fully Intergrated Frame
Hardware:	Stainless Steel & Aluminum	Stainless Steel & Aluminum	Stainless Steel & Aluminum
Roof Construction:	One Piece Aluminum Roof w/ Heavy Duty Radius Extrusion	One Piece Aluminum Roof w/ Heavy Duty Radius Extrusion	One Piece Aluminum Roof w/ Heavy Duty Radius Extrusion
Floor Construction:	12" O/C - Box Tube	12" O/C - Box Tube	12" O/C - Box Tube
Floor Material:	Extruded Aluminum Flooring	Extruded Aluminum Flooring	Extruded Aluminum Flooring
Running Boards:	N/A	Full Length Running Boards	Full Length Running Boards
Exterior:	.040 Pre-Painted Aluminum Skin (6 Available Colours)	.040 Pre-Painted Aluminum Skin (6 Available Colours)	.040 Pre-Painted Aluminum Skin (6 Available Colours)
Graphics:	Custom Graphic Package	Custom Graphic Package	Custom Graphic Package
Kick Panel:	Heavy Duty Wall Liner	Heavy Duty Wall Liner	Heavy Duty Wall Liner
Exterior Lighting:	All LED Lights	All LED Lights	All LED Lights
Axles:	Tandem 3500K Dexter Torsion Ride Axles	Tandem 3500K Dexter Torsion Ride Axles	Tandem 3500K Dexter Torsion Ride Axles
Brakes:	4 Wheel Electric Brakes w/ Safety Break-Away Kit	4 Wheel Electric Brakes w/ Safety Break-Away Kit	4 Wheel Electric Brakes w/ Safety Break-Away Kit
Bumper:	N/A	N/A	Rear Rubber Bumper
Landing Gear:	Top-Winding Pedestal Jack	Top-Winding Pedestal Jack	Top-Winding Pedestal Jack





All-Aluminum Horse Trailers Made in New England

# COLT SERIES



Colt 2-Horse Model



Colt 2-Horse Model



Colt 3-Horse Tack Room



Colt 3-Horse Interior



Colt 3-Horse Model

## ~ STANDARD FEATURES ~

HORSE AREA

FRONT TACK AREA

	Colt 2-Horse	Colt 3-Horse
Removable - Solid Head and Shoulder Divider with Telescoping Last Stall w/ Pads	X	X
Drop Down Feed Window w/ Face Grill per Stall	X	X
2 x Air Gaps w/ Plexiglass on Rump Side and Rear Gate	X	X
1/2" Rubber Floor Mats	X	X
36" Heavy Duty Rump Wall Liner	X	X
Full Swing Rear Gate w/Air Gap and Plexiglass	X	X
2 Inside Tie Rings and 1 Outside Tie Ring per Horse	X	X
1 Interior Dome Light w/ Rear Loading Switch	X	X
Double Action, Pop-up Vent per Horse Stall	X	X
32" x 72" Tack Storage Door w/ Sliding Window	X	X
1/2" Rubber Floor Mats	X	X
1 Interior Dome Light w/ Wall Switch	X	X
6 x Adjustable Bridle Hooks	X	X
One Adjustable/Removable Saddle Rack per Stall	X	X
32" x 72" Tack Storage Door w/ Sliding Window	X	X





All-Aluminum Horse Trailers Made in New England

**COLT SERIES**



Curb Side

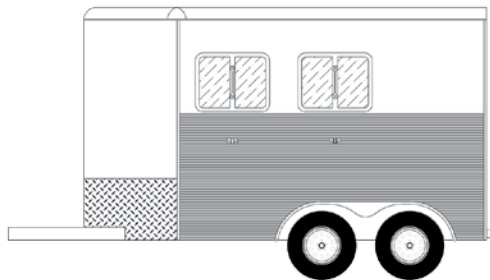

Driver Side

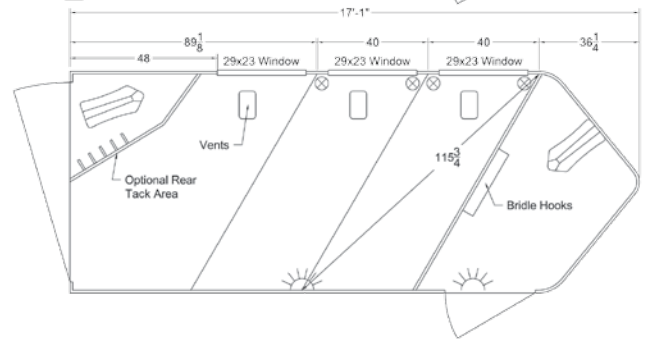
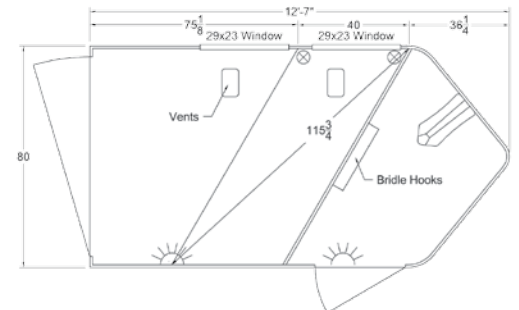
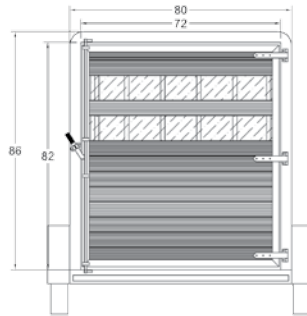

**~ STANDARD SPECIFICATIONS ~**

	Colt 2-Horse	Colt 3-Horse
Coupler:	Bumper Pull, 2 5/16"	Bumper Pull, 2 5/16"
Box Length:	12'8"	16'8"
Trailer Width:	6'8"	6'8"
Inside Height:	7'0"	7'0"
Number of Horses:	2	3
Load Type:	Slant Load - Step Up	Slant Load - Step Up
Stall Width:	40 1/2"	40 1/2"
Stall Length:	84"	84"
Style:	Bumper Pull, V-Nose Construction with 24" Stone Guard	Bumper Pull, V-Nose Construction with 24" Stone Guard
Construction:	100% Box Tube Aluminum Fully Intergrated Frame	100% Box Tube Aluminum Fully Intergrated Frame
Hardware:	Stainless Steel & Aluminum	Stainless Steel & Aluminum
Roof Construction:	One Piece Aluminum Roof w/ Heavy Duty Radius Extrusion	One Piece Aluminum Roof w/ Heavy Duty Radius Extrusion
Floor Construction:	12" O/C - Box Tube	12" O/C - Box Tube
Floor Material:	Extruded Aluminum Flooring	Extruded Aluminum Flooring
Windows:	Drop Down Window w/ Face Grill per Stall	Drop Down Window w/ Face Grill per Stall
Exterior Top:	.040 Aluminum Driver's Side Top and V-Nose	.040 Aluminum Driver's Side Top and V-Nose
Exterior Bottom:	Extruded Aluminum Sides	Extruded Aluminum Sides
Air Gaps:	2 x Air Gaps w/ Plexiglass on Rump Side and Rear Gate	2 x Air Gaps w/ Plexiglass on Rump Side and Rear Gate
Kick Panel:	Heavy Duty Wall Liner	Heavy Duty Wall Liner
Exterior Lighting:	All LED Lights	All LED Lights
Axles:	Tandem 3500K Dexter Torsion Ride Axles	Tandem 3500K Dexter Torsion Ride Axles
Brakes:	4 Wheel Electric Brakes w/ Safety Break-Away Kit	4 Wheel Electric Brakes w/ Safety Break-Away Kit
Bumper:	Rear Rubber Bumper	Rear Rubber Bumper
Landing Gear:	Top-Winding Pedestal Jack	Top-Winding Pedestal Jack





All-Aluminum Horse Trailers Made in New England

# STRIDER SERIES



Strider 2-Horse



Strider 2-Horse Exterior



Strider 2-Horse Interior



Strider 3-Horse



Strider 3-Horse Exterior



Strider 3-Horse Interior



Strider 3-Horse Interior

## ~ STANDARD FEATURES ~

	Strider 2-Horse	Strider 3-Horse
<b>HORSE AREA</b>		
Solid Head and Shoulder Divider with Telescoping Last Stall w/ Pads	X	X
Drop Down Feed Window w/ Face Grill per Stall	X	X
Large Drop Down Feed Window w/ Bars on Rump Wall	X	X
1/2" Rubber Floor Mats	X	X
Heavy Duty Wall Liner & Rear Door Liner	X	X
50/50 Double Rear Doors w/ Sliding Windows	X	X
2 Inside Tie Rings and 1 Outside Tie Ring per Horse	X	X
1 Interior Dome Light w/ Rear Loading Switch	X	X
Double Action, Pop-up Vent per Horse Stall	X	X
<b>FRONT TACK AREA</b>		
32" x 72" Tack Storage Door w/ Sliding Window	X	X
1/2" Rubber Floor Mats	X	X
1 Interior Dome Light w/ Wall Switch	X	X
6 x Adjustable Bridle Hooks	X	X
Wall Mounted Blanket Bar	X	X
Brush Tray Mounted on Tack Storage Door	X	X
Swing Out Saddle Rack, One Rack per Stall	X	X







All-Aluminum Horse Trailers Made in New England

# STRIDER SERIES

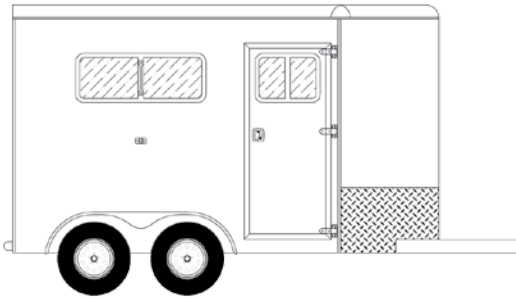

Curb Side

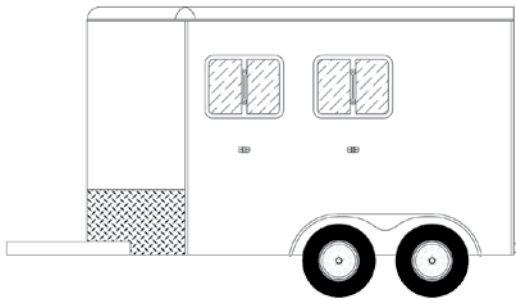

Driver Side

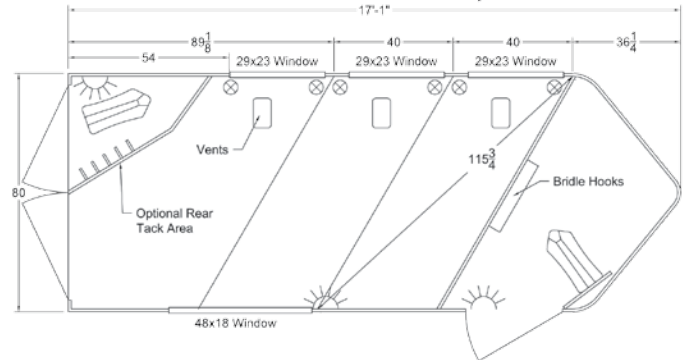
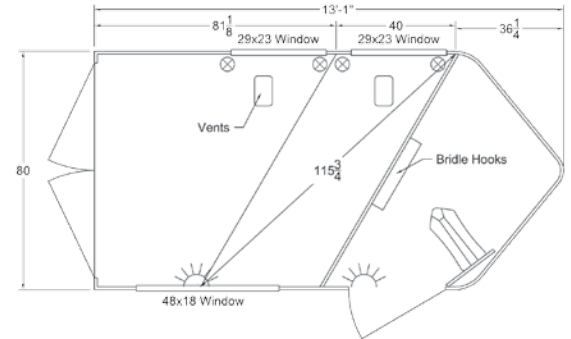
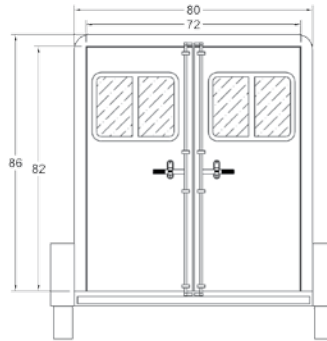

## ~ STANDARD SPECIFICATIONS ~

	Strider 2-Horse	Strider 3-Horse
Coupler:	Bumper Pull, 2.5/16"	Bumper Pull, 2.5/16"
Box Length:	12'8"	16'7"
Trailer Width:	6'8"	6'8"
Inside Height:	7'0"	7'0"
Number of Horses:	2	3
Load Type:	Slant Load - Step Up	Slant Load - Step Up
Stall Width:	40 1/2"	40 1/2"
Stall Length:	84"	84"
Style:	Bumper Pull, V-Nose Construction with 24" Stone Guard	Bumper Pull, V-Nose Construction with 24" Stone Guard
Construction:	100% Box Tube Aluminum Fully Intergrated Frame	100% Box Tube Aluminum Fully Intergrated Frame
Hardware:	Stainless Steel & Aluminum	Stainless Steel & Aluminum
Roof Construction:	One Piece Aluminum Roof w/ Heavy Duty Radius Extrusion	One Piece Aluminum Roof w/ Heavy Duty Radius Extrusion
Floor Construction:	12" O/C - Box Tube	12" O/C - Box Tube
Floor Material:	Extruded Aluminum Flooring	Extruded Aluminum Flooring
Windows:	Drop Down Window w/ Face Grill per Stall	Drop Down Window w/ Face Grill per Stall
Exterior:	.040 Pre-Painted Aluminum Skin (6 Available Colours)	.040 Pre-Painted Aluminum Skin (6 Available Colours)
Graphics:	Custom Graphics Package	Custom Graphics Package
Kick Panel:	Heavy Duty Wall Liner & Rear Door Liner	Heavy Duty Wall Liner & Rear Door Liner
Exterior Lighting:	All LED Lights	All LED Lights
Axles:	Tandem 3500K Dexter Torsion Ride Axles	Tandem 3500K Dexter Torsion Ride Axles
Brakes:	4 Wheel Electric Brakes w/ Safety Break-Away Kit	4 Wheel Electric Brakes w/ Safety Break-Away Kit
Bumper:	Rear Rubber Bumper	Rear Rubber Bumper
Landing Gear:	Top-Winding Pedestal Jack	Top-Winding Pedestal Jack





All-Aluminum Horse Trailers Made in New England

# FAST TRACK SERIES



## ~ STANDARD FEATURES ~

Solid Head and Shoulder Divider with Telescoping Last Stall w/ Pads

Large Sliding Window w/ Screen and Bars per Stall

1/2" Rubber Floor Mats

Heavy Duty Wall Liner (Double Wall Construction)

Spring Loaded Rear Ramp (rubber lined) w/ Wrap Around Tail Curtains

Spring Loaded Side Ramp (rubber lined) w/ Wrap Around Tail Curtains

2 Inside Tie Rings and 1 Outside Tie Ring per Horse

3 Interior Dome Lights in horse Area w/ Rear Loading Switch and Wall Switch

Double Action, Pop-up Vent per Horse Stall & Wall Switch

32" x 72" Escape Door in V-Nose (Driver's Side)

One Adjustable/Removeable Saddle Rack per Stall

6 x Adjustable Bridle Hooks

Enclosed Tack Area Optional





All-Aluminum Horse Trailers Made in New England

# FAST TRACK SERIES

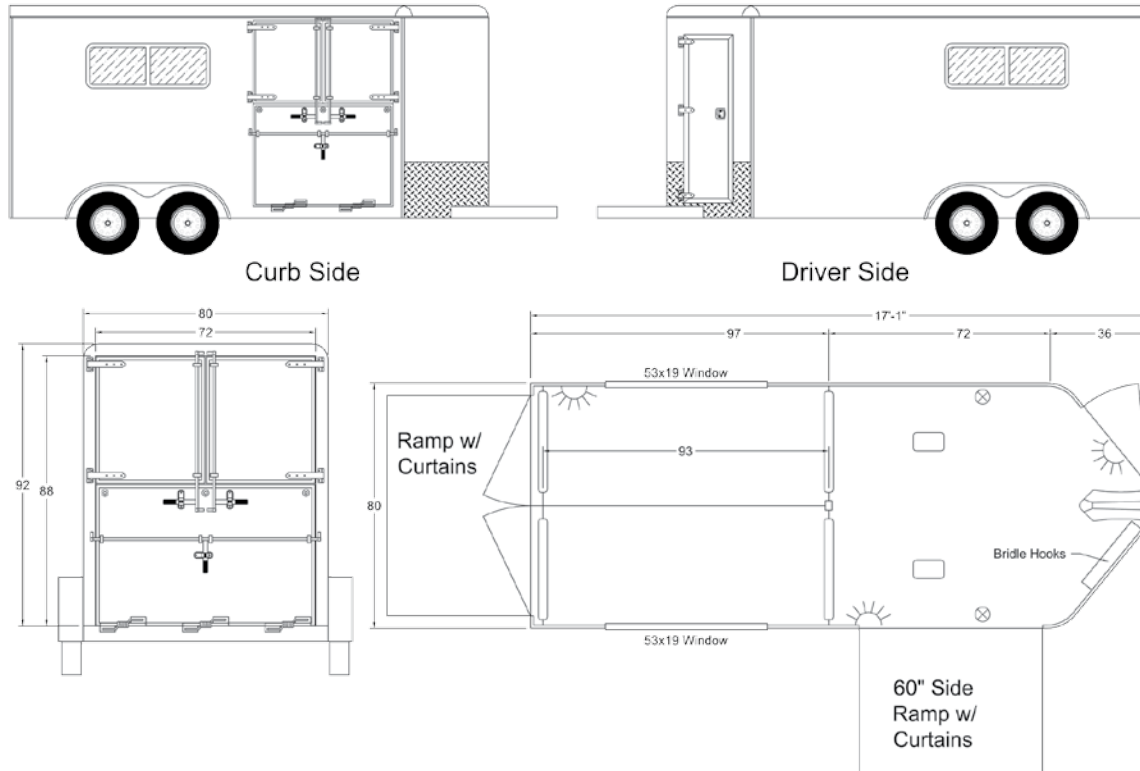

## ~ STANDARD SPECIFICATIONS ~

Coupler:	Bumper Pull, 2 5/16"
Box Length:	16'7"
Trailer Width:	6'8"
Inside Height:	7'6"
Number of Horses:	2
Load Type:	Straight Load - Rear Ramp
Stall Width:	37 1/2"
Stall Length:	84"
Style:	Bumper Pull, V-Nose Construction with 24" Stone Guard
Construction:	100% Box Tube Aluminum Fully Intergrated Frame
Hardware:	Stainless Steel & Aluminum
Roof Construction:	One Piece Aluminum Roof w/ Heavy Duty Radius Extrusion
Floor Construction:	12" O/C - Box Tube
Floor Material:	Extruded Aluminum Flooring
Exterior:	.040 Pre-Painted Aluminum Skin (14 Available Colours)
Graphics:	Custom Graphic Package
Kick Panel:	Heavy Duty Wall Liner
Exterior Lighting:	All LED Lights
Axles:	Tandem 3500K Dexter Torsion Ride Axles
Brakes:	4 Wheel Electric Brakes w/ Safety Break-Away Kit
Landing Gear:	Top-Winding Pedestal Jack







All-Aluminum Horse Trailers Made in New England

# LIVESTOCK SERIES



Livestock 14' Model  
\*shown w/ options



Livestock 14' Model Exterior



Livestock 14' Model Interior



Livestock 16' Model Exterior



Livestock 16' Model Interior



Livestock 16' Model

## ~ STANDARD FEATURES ~

2 x Air Gaps w/ Plexiglass Track

Optional 2" Rubber Flooring

Full Swing Rear Gate w/Air Gap and Plexiglass Track

Swinging Center Gate (Standard 16' Model)

1 Interior Dome Light w/ Rear Loading Switch

32" x 72" Side Access Door w/ Locking Bar





All-Aluminum Horse Trailers Made in New England

# LIVESTOCK SERIES

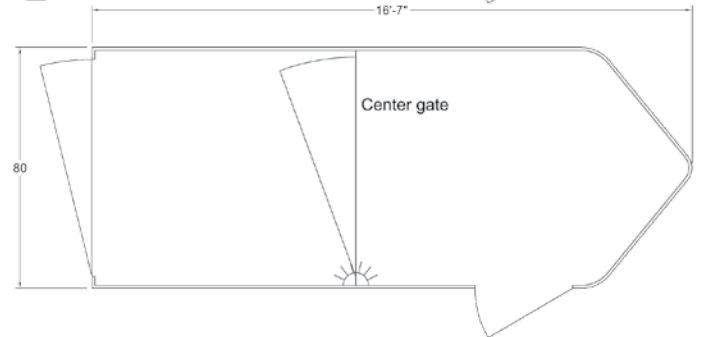
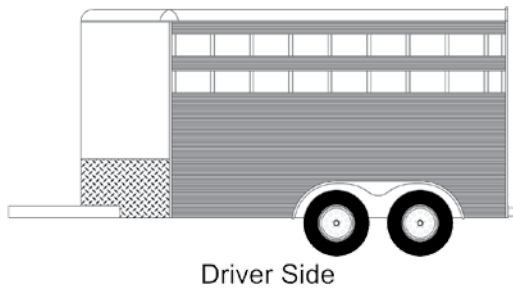
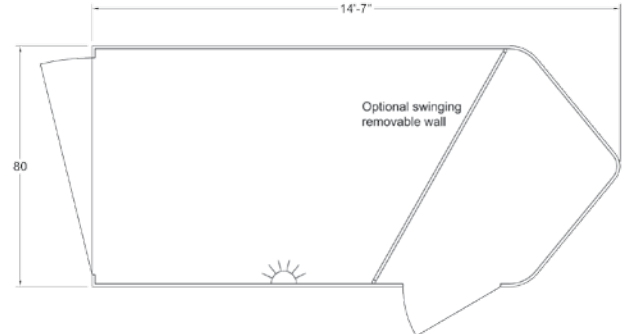
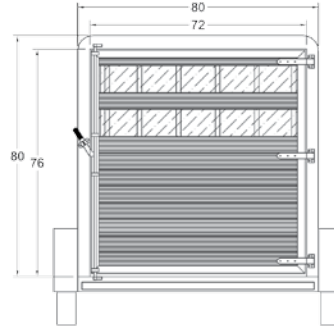
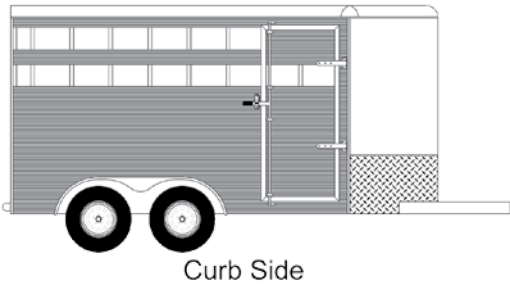

## ~ STANDARD SPECIFICATIONS ~

	Livestock 14'	Livestock 16'
Coupler:	Bumper Pull, 2.5/16"	Bumper Pull, 2.5/16"
Box Length:	14'7"	16'7"
Trailer Width:	6'8"	6'8"
Inside Height:	6'6"	6'6"
Load Type:	Step Up	Step Up
Style:	Bumper Pull, V-Nose Construction with 24" Stone Guard	Bumper Pull, V-Nose Construction with 24" Stone Guard
Construction:	100% Box Tube Aluminum Fully Intergrated Frame	100% Box Tube Aluminum Fully Intergrated Frame
Hardware:	Stainless Steel & Aluminum	Stainless Steel & Aluminum
Roof Construction:	One Piece Aluminum Roof w/ Heavy Duty Radius Extrusion	One Piece Aluminum Roof w/ Heavy Duty Radius Extrusion
Floor Construction:	12" O/C - Box Tube	12" O/C - Box Tube
Floor Material:	Extruded Aluminum Flooring	Extruded Aluminum Flooring
Exterior:	Extruded Aluminum Sides	Extruded Aluminum Sides
Exterior Skin V-Nose:	.050 Aluminum V-Nose	.050 Aluminum V-Nose
Air Gaps:	2 x Air Gaps w/ Plexiglass Tracks	2 x Air Gaps w/ Plexiglass Tracks
Exterior Lighting:	All LED Lights	All LED Lights
Axles:	Tandem 3500K Dexter Torsion Ride Axles	Tandem 3500K Dexter Torsion Ride Axles
Brakes:	4 Wheel Electric Brakes w/ Safety Break-Away Kit	4 Wheel Electric Brakes w/ Safety Break-Away Kit
Bumper:	Rear Rubber Bumper	Rear Rubber Bumper
Landing Gear:	Top-Winding Pedestal Jack	Top-Winding Pedestal Jack





Star Lite Interior



Star Lite Exterior



Star Lite Rear Doors



Star Lite Tack Area

**~ STANDARD FEATURES ~**

Solid Head and Shoulder Divider with Telescoping Last Stall w/ Pads

Large Sliding Window w/ Screen and Bars per Stall

1/2" Rubber Floor Mats

Heavy Duty Wall Liner (Double Wall Construction)

Overlapping Rear Doors

2 Inside Tie Rings and 1 Outside Tie Ring per Horse

3 Interior Dome Lights Area w/ Rear Loading Switch and Wall Switch

Double Action, Pop-up Vent per Horse Stall & Wall Switch

32" x 72" Escape Door in V-Nose

One Adjustable/Removeable Saddle Rack per Stall

6 x Adjustable Bridle Hooks





All-Aluminum Horse Trailers Made in New England

# STAR LITE SERIES

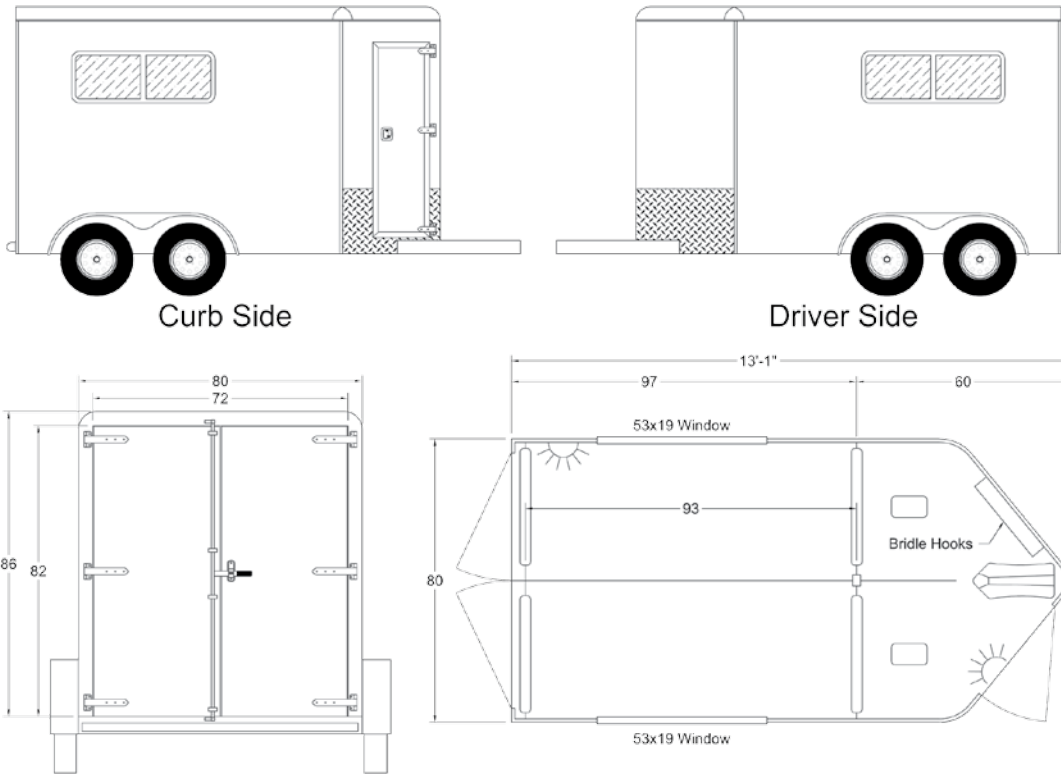

## ~ STANDARD SPECIFICATIONS ~

Coupler:	Bumper Pull, 2 5/16"
Box Length:	12'7"
Trailer Width:	6'8"
Inside Height:	7'
Number of Horses:	2
Load Type:	Straight Load - Step Up
Stall Width:	37 1/2"
Stall Length:	84"
Style:	Bumper Pull, V-Nose Construction with 24" Stone Guard
Construction:	100% Box Tube Aluminum Fully Intergrated Frame
Hardware:	Stainless Steel & Aluminum
Roof Construction:	One Piece Aluminum Roof w/ Heavy Duty Radius Extrusion
Floor Construction:	12" O/C - Box Tube
Floor Material:	Extruded Aluminum Flooring
Exterior:	.040 Pre-Painted Aluminum Skin (14 Available Colours)
Graphics:	Custom Graphic Package
Kick Panel:	Heavy Duty Wall Liner
Exterior Lighting:	All LED Lights
Axles:	Tandem 3500K Dexter Torsion Ride Axles
Brakes:	4 Wheel Electric Brakes w/ Safety Break-Away Kit
Bumper:	Rear Rubber Bumper
Landing Gear:	Top-Winding Pedestal Jack

